

Hi-MO 6

Explorer

LR5-54HTH 415~430M

- Suitable for distributed projects
- Excellent outdoor power generation performance
- High module quality ensures long-term reliability



15-year Warranty for
Materials and Processing



25-year Warranty for Extra
Linear Power Output

Complete System and Product Certifications

IEC 61215, IEC 61730, UL 61730

ISO9001:2015: ISO Quality Management System

ISO14001: 2015: ISO Environment Management System

ISO45001: 2018: Occupational Health and Safety

IEC62941: Guideline for module design qualification and type approval

LONGI



22.0%
MAX MODULE
EFFICIENCY

0~3%
POWER
TOLERANCE

<1.5%
FIRST YEAR
POWER DEGRADATION

0.40%
YEAR 2-25
POWER DEGRADATION

Additional Value

25-Year Power Warranty

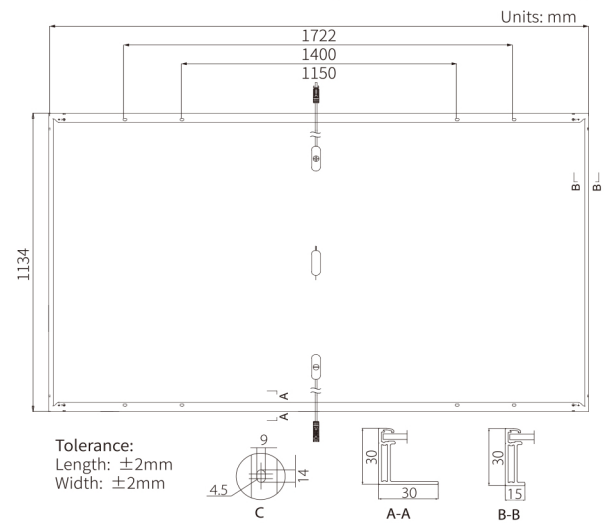
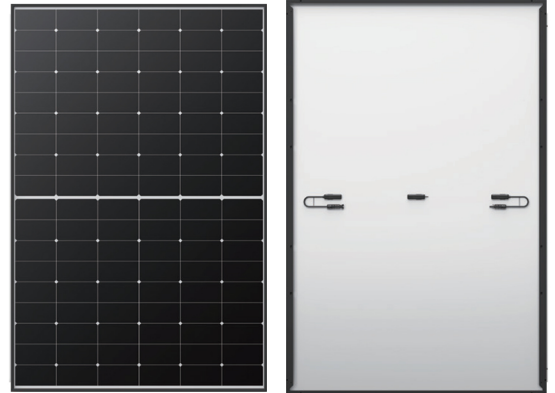
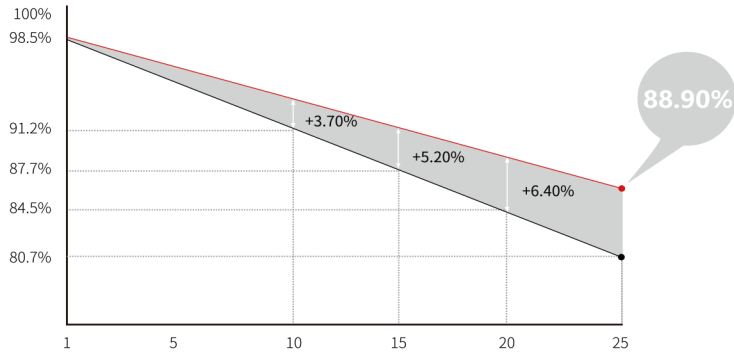

Mechanical Parameters

| | |
|------------------|--|
| Cell Orientation | 108 (6×18) |
| Junction Box | IP68, three diodes |
| Output Cable | 4mm ² , ± 1200 mm length can be customized |
| Glass | Single glass, 3.2mm coated tempered glass |
| Frame | Anodized aluminum alloy frame |
| Weight | 20.8kg |
| Dimension | 1722×1134×30mm |
| Packaging | 36pcs per pallet / 216pcs per 20' GP / 936pcs per 40' HC |

Electrical Characteristics

STC : AM1.5 1000W/m² 25°C

NOCT : AM1.5 800W/m² 20°C 1m/s

Test uncertainty for Pmax: $\pm 3\%$

| Module Type | LR5-54HTH-415M | | LR5-54HTH-420M | | LR5-54HTH-425M | | LR5-54HTH-430M | |
|----------------------------------|----------------|-------|----------------|-------|----------------|-------|----------------|-------|
| | STC | NOCT | STC | NOCT | STC | NOCT | STC | NOCT |
| Testing Condition | STC | NOCT | STC | NOCT | STC | NOCT | STC | NOCT |
| Maximum Power (Pmax/W) | 415 | 310 | 420 | 314 | 425 | 318 | 430 | 321 |
| Open Circuit Voltage (Voc/V) | 38.53 | 36.18 | 38.73 | 36.36 | 38.93 | 36.55 | 39.13 | 36.74 |
| Short Circuit Current (Isc/A) | 13.92 | 11.24 | 14.00 | 11.31 | 14.07 | 11.36 | 14.15 | 11.43 |
| Voltage at Maximum Power (Vmp/V) | 32.24 | 29.42 | 32.44 | 29.60 | 32.64 | 29.78 | 32.84 | 29.97 |
| Current at Maximum Power (Imp/A) | 12.88 | 10.54 | 12.95 | 10.60 | 13.03 | 10.67 | 13.10 | 10.72 |
| Module Efficiency(%) | 21.3 | | 21.5 | | 21.8 | | 22.0 | |

Operating Parameters

| | |
|------------------------------------|-------------------------------|
| Operational Temperature | -40°C ~ +85°C |
| Power Output Tolerance | 0 ~ 3% |
| Voc and Isc Tolerance | $\pm 3\%$ |
| Maximum System Voltage | DC1500V (IEC/UL) |
| Maximum Series Fuse Rating | 25A |
| Nominal Operating Cell Temperature | 45 \pm 2°C |
| Protection Class | Class II |
| Fire Rating | UL type 1 or 2 IEC Class C |

Mechanical Loading

| | |
|-----------------------------------|--------------------------------------|
| Front Side Maximum Static Loading | 5400Pa |
| Rear Side Maximum Static Loading | 2400Pa |
| Hailstone Test | 25mm Hailstone at the speed of 23m/s |

Temperature Ratings (STC)

| | |
|---------------------------------|------------|
| Temperature Coefficient of Isc | +0.050%/°C |
| Temperature Coefficient of Voc | -0.230%/°C |
| Temperature Coefficient of Pmax | -0.290%/°C |